

STI FIRE EXTINGUISHER THEFT STOPPER®



STI-6200

PRODUCT OVERVIEW

If you are fed up with replacing your fire extinguishers, this sturdy, tamperproof, self-contained alarm is the answer. It has proven highly effective in helping stop theft, misuse or vandalism of fire extinguishers. Yet, it leaves the extinguisher accessible for emergencies and does not interfere with fire fighting in any way.

HOW IT WORKS

If the protected fire extinguisher is moved from its normal position, the device emits a piercing alarm. Also, the highly visible stop sign design and the words "STOP, EMERGENCY USE ONLY" discourages wrongful use. The device is easy to install and a deactivation cable is supplied for ease in servicing the extinguisher. A 9 VDC alkaline battery is included.

KEY FEATURES

General Information

- Highly visible "stop sign" design discourages wrongful use of extinguisher.
- Deactivation cable provided for service by authorized personnel.
- Three year guarantee against breakage of polycarbonate in normal use (one year on electro mechanical and electronic components).

Design

- Compact design 5.375 in. (137mm) in diameter and 2 in. (51mm deep). Mounts easily next to extinguisher.

Construction

- Virtually indestructible polycarbonate housing.

Installation

- For fire extinguishers housed in cabinets, refer to STI-6255 Mini Theft Stopper®.

Electronics

- Sounds a powerful 105 dB warning horn when activated, drawing attention in a hurry (95 dB low volume setting can be set if desired).
- 9 VDC alkaline battery is provided.

Options

- STI-6200WIR supervised wireless 433 MHz (4 or 8-Channel Receiver required). Operates up to 1000' (line of sight).
- Remote powered 12 VDC model available for special applications (STI-6200R).



For more information, call 1-800-888-4784 (4STI) or visit www.sti-usa.com



**Safety Technology
International, Inc.**

STI Fire Extinguisher Theft Stopper®

Dimensions and Technical Information

MODELS AVAILABLE

- STI-6200** Fire Extinguisher Theft Stopper
- STI-6200R** Fire Extinguisher Theft Stopper with 12 volt, remote powered horn
- STI-6200WIR** Wireless Fire Extinguisher Theft Stopper
- STI-6200WIR4** Wireless Fire Extinguisher Theft Stopper with 4-Channel Receiver
- STI-6200WIR8** Wireless Fire Extinguisher Theft Stopper with 8-Channel Receiver
- STI-V6200WIR4** Wireless Fire Extinguisher Theft Stopper with 4-Channel Voice Receiver
- STI-34104** 4-Channel Receiver
- STI-34108** 8-Channel Voice Receiver
- STI-V34104** 4-Channel Receiver
- STI-30104** Lamp Controller
- 18015-9** 6 in. deactivation cable used during service times
- 18015-RC** Replacement cable and crimp 16-18 in. long

APPROVALS & WARRANTY

- STI-6200, STI-6200WIR & STI-6200WIR4**
It has been tested and approved or listed by:
- FCC & IC Compliant
 - CE Approved

WARRANTY

Three year guarantee against breakage of polycarbonate in normal use (one year on electro mechanical and electronic components).

PRODUCT INFORMATION

- This sturdy, tamper resistant, self-contained device helps prevent the theft or vandalism of fire extinguishers. Experience has shown its highly visible "stop sign" design is itself an effective deterrent. The device contains a 9 VDC battery (included), a selectable 95 or 105 dB horn and a unique steel cable operated switch mechanism. When the extinguisher is removed, the galvanized steel cable is pulled out of the alarm and the horn sounds.
- Reduces theft of vital fire extinguishers
 - Reduces vandalism of fire extinguishers
 - Completely self-contained
 - Does not interfere with fire fighting in any way
 - Remote powered 12 VDC version available
 - Lifetime warranty against breakage of polycarbonate housing

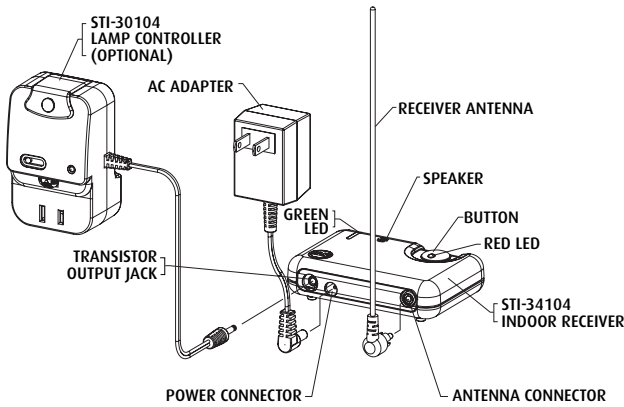

STI-34104

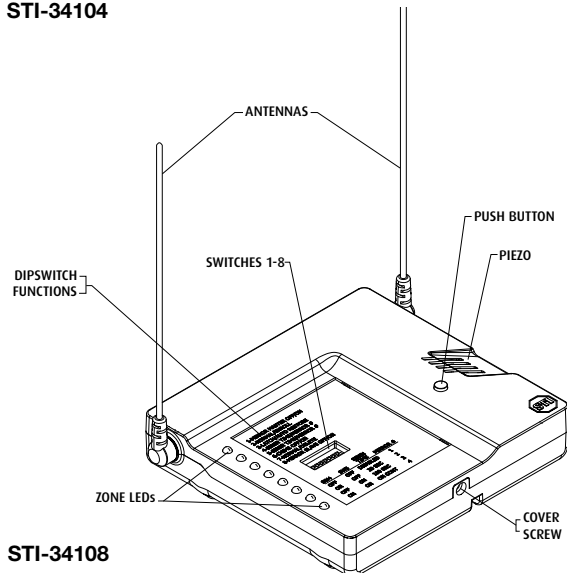

STI-34108

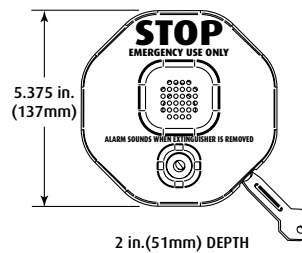
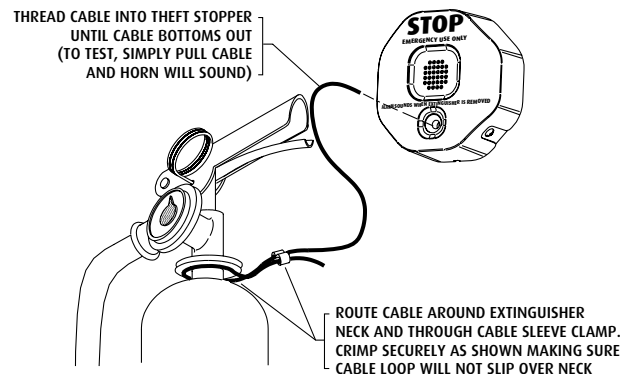

Safety Technology International, Inc.

2306 Airport Road
Waterford, Michigan
48327, USA

Tel: 248-673-9898
Fax: 248-673-1246
Toll-free: 800-888-4784
info@sti-usa.com
www.sti-usa.com

Unit 49G Pipers Road
Park Farm Industrial Estate
Redditch, Worcestershire
B98 0HU England

Tel: 44 (0) 1527 520 999
Fax: 44 (0) 1527 501 999
info@sti-europe.com
www.sti-europe.com